

18th



International Chemistry Olympiad

**7 theoretical problems
2 practical problems**

THE EIGHTEENTH INTERNATIONAL CHEMISTRY OLYMPIAD 6–15 JULY 1986, LEIDEN, NETHERLANDS

THEORETICAL PROBLEMS

PROBLEM 1

Compounds containing divalent platinum with the general formula $\text{PtX}_2(\text{amine})_2$ ($X = \text{Cl}_2, \text{SO}_4^{2-}, \text{malonate}, \text{etc.}$) have met a lot of scientific interest because of their biological activity, particularly in view of their properties in the treatment of tumours. The best known compound used clinically is $\text{PtCl}_2(\text{NH}_3)_2$. This compound, in which platinum is coordinated in a planar square, has two geometrical isomers of which only one shows the antitumour activity.

- 1.1 Sketch the spatial structures of the two possible isomers.
1.2 How many isomers has $\text{PtBrCl}(\text{NH}_3)_2$? Sketch all of them.

It is possible to replace the amine ligands by one ligand containing two donor atoms (N). Then one obtains a chelating ligand, such as 1,2-diaminoethane (en).

- 1.3 Show graphically that $\text{PtBrCl}(\text{en})$ has only one stable structure.

The ligand en can be substituted via methylation to form dmen or pn (racemic).

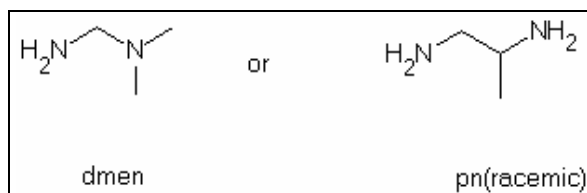

- 1.4 Give spatial structures of all isomers of the following compounds: $\text{PtCl}_2(\text{dmen})$, $\text{PtCl}_2(\text{pn})$, $\text{PtBrCl}(\text{dmen})$ and $\text{PtBrCl}(\text{pn})$.

These compounds can isomerise in aqueous solution through dissociation of a ligand and transient replacement of the stronger ligands by the weak ligand water. Cl^- and Br^- are

replaced relatively easily, but it is more difficult to replace the amine ligands, which usually requires heating.

- 1.5** Considering each of the isomers in the previous questions a-d, indicate which isomers can be converted to another at room temperature. Give both the original molecule and the products.
- 1.6** $\text{PtCl}_2(\text{en})$ reacts with Br^- in a molar proportion of 1:2 at room temperature. Which compound would you expect to form in what proportion? You can assume that the Pt-Br and Pt-Cl bonds are equally strong and that there is no perturbing influence from hydrolysis.
- 1.7** Using the equation to express chemical equilibrium, show that hydrolysis hardly ever occurs in blood but that it does occur in the cells. Note: $\text{PtCl}_2(\text{NH}_3)_2$ hydrolyses to and 2 Cl^- . In cells the Cl^- concentration is low; in blood it is fairly high.

After hydrolysis in the tumour cell a reactive platinum ion is formed to which two NH_3 groups are still bound, as it was found in the urine of patients treated with this compound. The reactive platinum ion appears to be bound to cellular DNA, where the bonding occurs via guanine to one of the N-atoms.

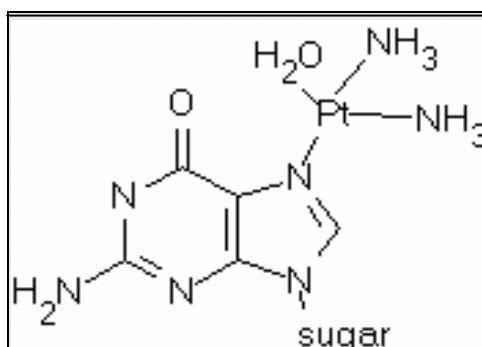

As a result of the two reactive sites of platinum and the two unreactive NH_3 ligands, it can form additionally a second bond to DNA. Research has shown that this happens in particular with a second guanine base from the same strand of DNA.

- 1.8** Show by calculations which of the two isomers in question a) can form this bond. (Note: Pt-N distance = 210 pm, DNA base distance = 320 pm).

SOLUTION

1.1 - 1.3 The isomers are:

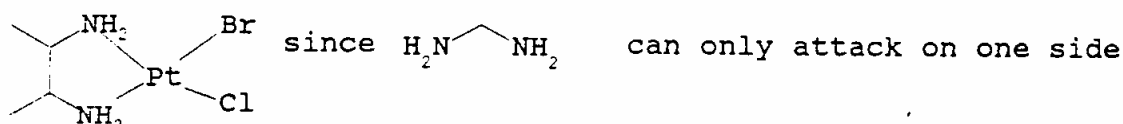
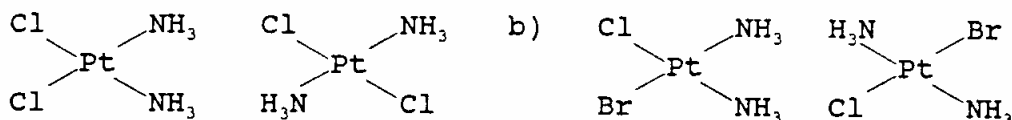

1.4

d) The following 9 isomers are possible:

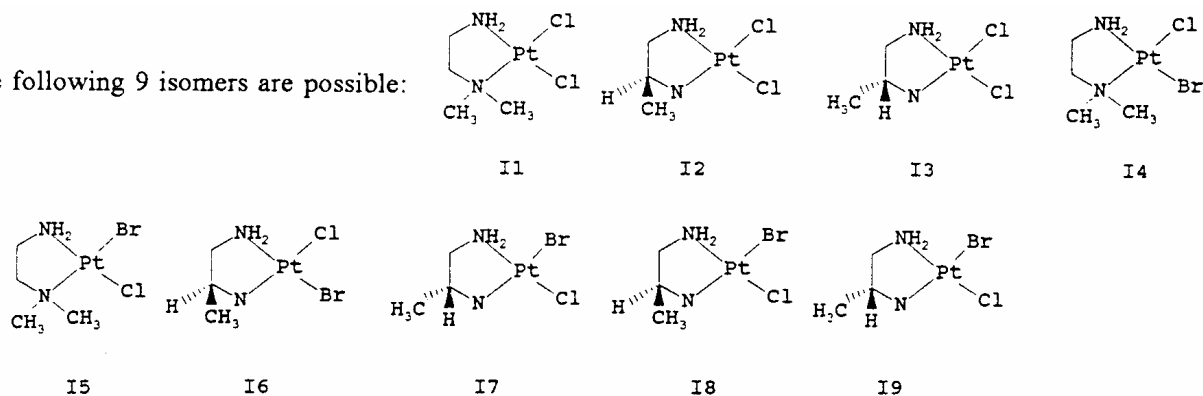

1.5 In a-c) there is no change possible;

in d) I4 and I5, I6 and I7, I8 and I9 transform one into another. Via this isomerization also $\text{PtCl}_2(\text{dmen})$, $\text{PtBr}_2(\text{dmen})$, $\text{PtCl}_2(\text{pn})$ and $\text{PtBr}_2(\text{pn})$ can be formed, even though they are not isomers.

1.6 $\text{PtCl}_2(\text{en}) : \text{PtBr}_2(\text{en}) : \text{PtBrCl}(\text{en}) = 1 : 1 : 2$

1.7 $\text{PtCl}_2(\text{NH}_3)_2 \rightleftharpoons (\text{PtCl}(\text{H}_2\text{O})(\text{NH}_3)_2)^+ \rightleftharpoons \text{Pt}(\text{H}_2\text{O})_2(\text{NH}_3)_2^{2+}$

In blood the hydrolysis does not occur, because the concentration of Cl^- is rather high and the equilibrium is shifted to the left side.

1.8 The bond is formed by the cis-isomer, because in that case the distance between the bases (320 pm) has to change only to $210\sqrt{2} = 297$ nm, whereas in the case of the trans-compound the distant would be $210 \times 2 = 420$ nm.

PROBLEM 2

The compound $\text{Na}_5\text{P}_3\text{O}_{10}$ is used as an additive for detergents to bind the Ca^{2+} and Mg^{2+} ions present in water in order to prevent the precipitation of their fatty acid salts on the laundry.

- 2.1 Draw the structure of the ions $(\text{P}_3\text{O}_{10})^{5-}$ and $(\text{P}_3\text{O}_9)^{3-}$ assuming that P-P bonds do not occur.
- 2.2 Assuming an octahedral coordination of the Mg^{2+} ion give a drawing of the $\text{Mg}(\text{P}_3\text{O}_{10})(\text{H}_2\text{O})_n^{3-}$ ion also indicating the value for n.

The complex ions of Mg^{2+} and Ca^{2+} and triphosphate are well soluble in water. They are, among other things, responsible for the wild growth of algae in surface waters. They could be removed by precipitation as an insoluble compound.

- 2.3 Give some possibilities (ions) to precipitate the triphosphates bound to Ca^{2+} or Mg^{2+} .
- 2.4 Calculate the mass of $\text{Na}_5\text{P}_3\text{O}_{10}$ (in grams) necessary in a washing machine to reduce the amount of Ca^{2+} in 20 litres of city water (0.225 g/l) to an acceptable maximum of 0.02 g/l. Effects of pH, the precipitation of $\text{Ca}(\text{OH})_2$, and possible effects by other positive ions, can be neglected. The following data is given:

$$K_1 = \frac{[\text{Ca}^{2+}][\text{P}_3\text{O}_{10}^{5-}]}{[\text{CaP}_3\text{O}_{10}^{3-}]} = 1.0 \times 10^{-6}$$

Molar mass of $\text{Na}_5\text{P}_3\text{O}_{10}$ is 366 g mol^{-1} , the molar mass of Ca is 40 g mol^{-1} .

SOLUTION

- 2.1 The structures are:

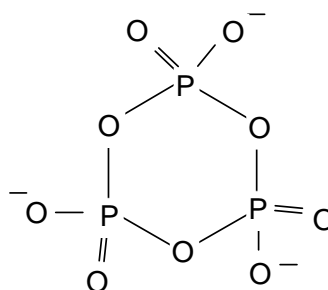
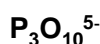
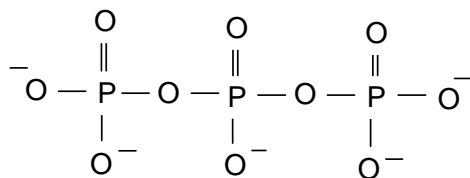

2.2 Since Mg^{2+} has the coordination number 6, one water molecule serves as the sixth ligand among the five O^- ligands already present in the $[\text{P}_3\text{O}_{10}]^{5-}$ - ligand:

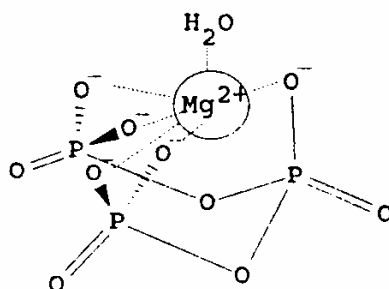

2.3 Possible ions are Al^{3+} or Fe^{2+} because of their equal charge and similar size. The triphosphates are not soluble in water.

$$2.4 \quad [\text{Ca}^{2+}] + [\text{CaP}_3\text{O}_{10}]^{3-} = \frac{0.225}{40} \text{ mol dm}^{-3};$$

$$[\text{Ca}^{2+}] = \frac{0.020}{40} \text{ mol dm}^{-3} \Rightarrow [\text{CaP}_3\text{O}_{10}^{3-}] = \frac{0.205}{40} \text{ mol dm}^{-3}$$

$$[\text{P}_3\text{O}_{10}^{5-}] = \frac{K_1[\text{CaP}_3\text{O}_{10}^{3-}]}{[\text{Ca}^{2+}]} = 1.025 \times 10^{-5} \text{ mol dm}^{-3}$$

$$[\text{CaP}_3\text{O}_{10}^{3-}] + [\text{P}_3\text{O}_{10}^{5-}] = 5.135 \times 10^{-3} \text{ mol dm}^{-3} \equiv 37.6 \text{ g Na}_3\text{P}_3\text{O}_{10} \text{ in } 20 \text{ dm}^3 \text{ H}_2\text{O}$$

PROBLEM 3

In order to explain why dyes are coloured, they can be considered as rod-like, one-dimensional molecules over which the electrons are distributed. The wave lengths of the electrons should fit to the available space which is the length l . When absorbing light, an electron makes a transition from a lower to a higher energy state. The energy difference is given by:

$$\Delta E = h \times \text{cover} \lambda \text{ where } \lambda = \frac{h}{p}$$

- 3.1 Give a general expression for possible wavelengths of the electron as a function of the length l .

In the 'particle in the box' model, only the variations in the kinetic energy of the electrons are considered.

- 3.2 Give an expression for the possible energies that electrons in the molecule can have (as a function of l).
- 3.3 Show that for a chain of length l with k electrons, the longest wavelength absorption occurs at:

$$\lambda = \frac{8mc l^2}{h(k+1)}$$

- 3.4 Derive an expression for the wavelength of the first electronic transition as a function of the number of C-atoms for even values of n .
- 3.5 Calculate the minimum number of C-atoms (conjugated systems) to obtain a visible colour. C-C bond length is 142 pm.

The retina in the human eye contains rhodopsin, a light absorbent.

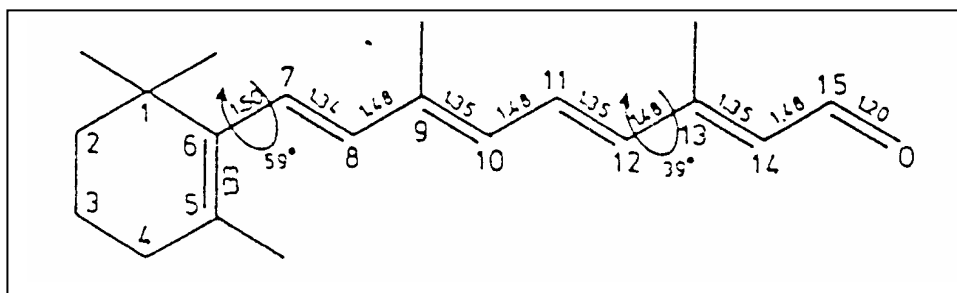

The molecule in the part of C-atoms 7 through 12 is planar. The angle between the bonds C5-C6, C7-C8, C11-C12 and C13-C14 is about 39°. According to the 'particle in the box' theory fragment C7 through C12 should absorb at about 213 nm. In reality the absorption of retinal occurs at 308 nm.

- 3.6** Give a reason for the longer wavelength that is observed in practice using the above mentioned theories.
- 3.7** When retinal is bound to opsin to form rhodopsin, the absorption occurs around 600 nm. Which atoms must be forced into one plane by the protein? Show by calculation that it's true.

SOLUTION

3.1 $\lambda = c\nu = 2l/n$ with $n = 1, 2, 3, \dots$

3.2 $E = \frac{hc}{\lambda} = \frac{mv^2}{2} = \frac{p^2}{2m}; p = \frac{h}{\lambda} = \frac{hn}{2l} \Rightarrow \Delta E_n = \frac{h^2 n^2}{8mI^2} = \frac{h^2}{8mI^2} \times (n_{\text{homo}}^2 - n_{\text{lumo}}^2)$

- 3.3** For k electrons and $k \equiv 0 \pmod{2}$, $k/2$ orbitals are possible, so $n_{\text{homo}} = k/2$ and $n_{\text{lumo}} = k/2 + 1$

$$\Delta E_n = \frac{h^2}{8mI^2} [(1/2k + 1)^2 - 1/2k^2] = \frac{h^2}{8mI^2} \times (k + 1) \Rightarrow \lambda = \frac{hc}{\Delta E} = \frac{8mcI^2}{h(k + 1)}$$

- 3.4** If N is the number of C-atoms, N is equal to $k+1$ for even number of electrons k , so

$$\lambda = \frac{8mcI^2}{Nh} = \frac{8mcI^2}{h(k + 1)}$$

for even N 's, the length of the box would be $a(N-1)$ with $k = N$ electrons, so

$$\lambda = \frac{8mc(N1)^2 a^2}{h(N+1)}$$

- 3.5** For a conjugated system N has to be even. To obtain a visible colour, the wavelength should be greater than 400 nm. Therefore:

$$\frac{8mc(N1)^2 a^2}{h(N+1)} \geq 4 \times 10^7 \text{ so accordingly : } \frac{(N1)^2}{N+1} \geq 6.02$$

The equation $N^2 - 6.02 N - 6.02 > 0$ derived from the equation above has the only positive solution $N = 8.60$. Since N must be even, the minimum number of C-Atoms is 10.

3.6 The angles between 5-6 and 7-8, as well as between 11-12 and 13-14 are smaller than 90° and therefore the effect of the double bonds between C5 and C6, C13, C14 and O cannot be neglected. They overlap to a small extent with the conjugated system C7 through C12 and enlarge the box significantly. A larger l leads to a larger λ , causing a shift towards a longer wavelength.

3.7 Obviously, the box must be much larger when bound to opsin. For $\lambda = 600$ nm the atoms C5 to O at the end of the chain must be forced into the plane:

$$l = 0.133 + 0.150 + 4(0.134 + 0.148) + 0.120 = 1.54 \text{ nm}; \quad k = 12;$$

$$\lambda = 3.30 \times 10^{12} l^2 / (k + 1) = \underline{602 \text{ nm}}$$

PROBLEM 4

The high efficiency of catalysis by enzymes is mainly due to an enzyme-reactant complex in which the reacting group is placed in a favourable position for the reaction with respect to the catalyzing groups of the enzyme. Studies are carried out with model compounds in which a catalyzing group has been introduced in the proximity of the reaction centre of the molecule. As an example we consider the hydrolysis of the amide bond in compound **A**. This reaction proceeds in water at 39 °C and pH = 2 more than a million times faster than the hydrolysis of compound **B**.

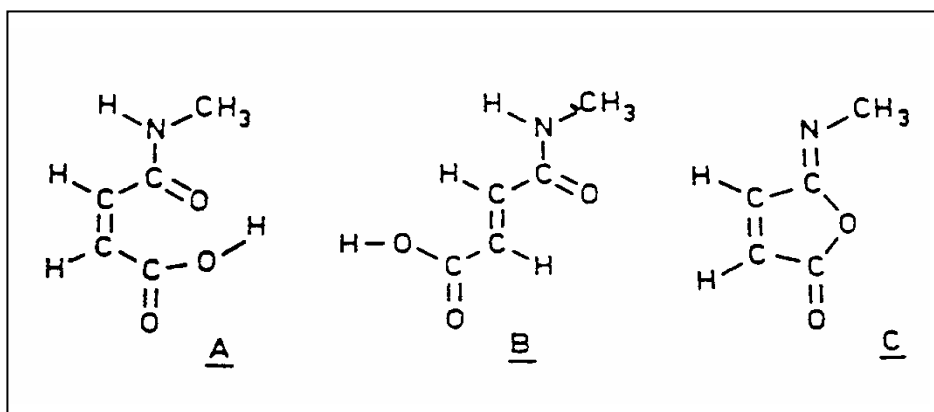

The relation between the rate constant k_{hyd} and pH for the hydrolysis of **A** at 39 °C is shown in figure below.

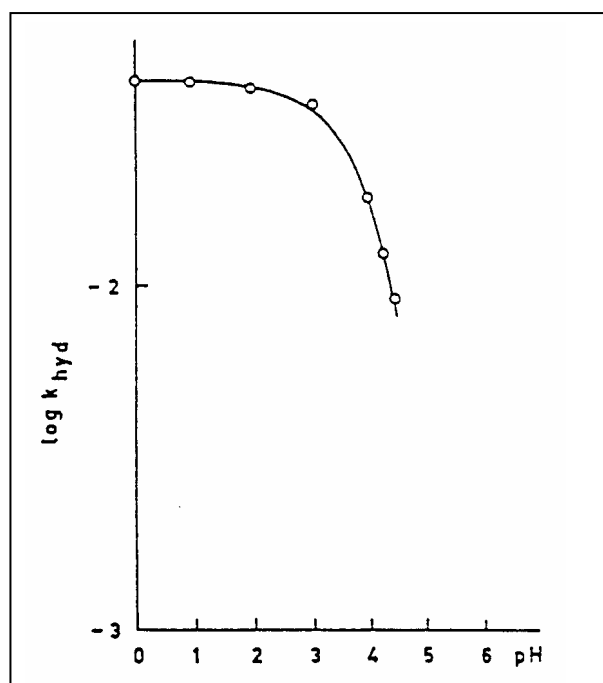

Further observation:

Addition of water to the iso-imide **C** gives a rapid reaction, which initially yields **A**. Subsequently, hydrolysis of **A** occurs. The amid carbonyl group in **A** is labelled with ¹³C and the hydrolysis is allowed to take place in H₂¹⁸O at pH = 2 and 39 °C. The diacid formed upon hydrolysis is isolated, converted into a disilver salt and completely decarboxylated with bromine in an anhydrous reaction medium. The carbon dioxide formed is a mixture of particles of masses 44, 45, 46 and 47 which are formed in equal amounts.

- 4.1 Why is the hydrolysis of **A** so much faster than that of **B**?
- 4.2 Explain why the rate of hydrolysis of **A** is independent on pH in the range between pH = 0 to pH = 2.
- 4.3 Why does k_{hyd} decrease so rapidly at pH values higher than 3.
- 4.4 Give a detailed reaction mechanism for the hydrolysis of **A**. Indicate which step in the reaction is rate determining.
- 4.5 Show that the observations further made are consistent with the reaction mechanism given under d.

SOLUTION

- 4.1 The high rate of hydrolysis of **A** is caused by intramolecular catalysis of the COOH group in the cis-position. In **B** the COOH group is situated in the trans-position with respect to the amide group and therefore too far away for intramolecular catalysis.
- 4.2 For $0 < \text{pH} < 2$ the COOH group is not ionized and therefore, it can act as an intramolecular catalyser. If the hydrolysis in that pH-range is only the result of catalysis by the COOH-group and not competing with H₃O⁺ the rate constant in that range is pH independent.
- 4.3 At $\text{pH} > 3$ the COOH group deprotonates giving COO⁻. Intramolecular acid catalysis, in which proton transfer plays an important role, is then not possible anymore.
- 4.4 The mechanism of hydrolysis is indicated below:

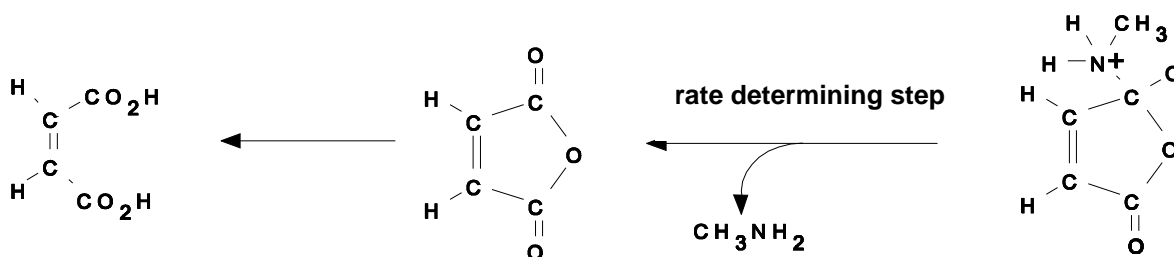
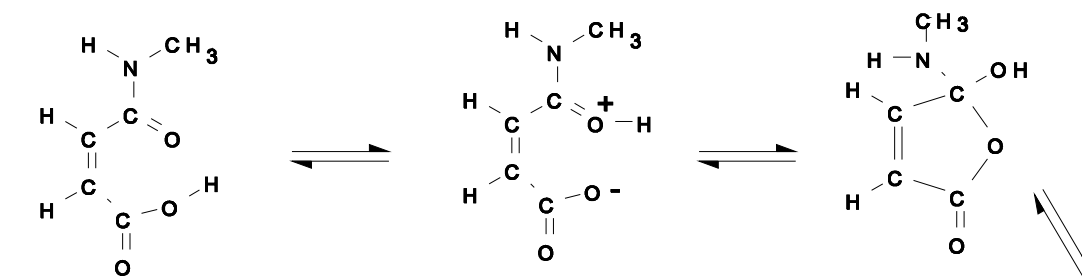

4.5

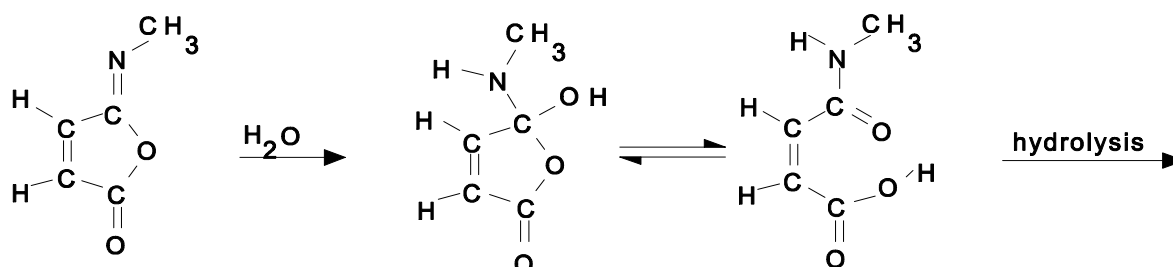

With the observation given, the rate determining step can be identified.

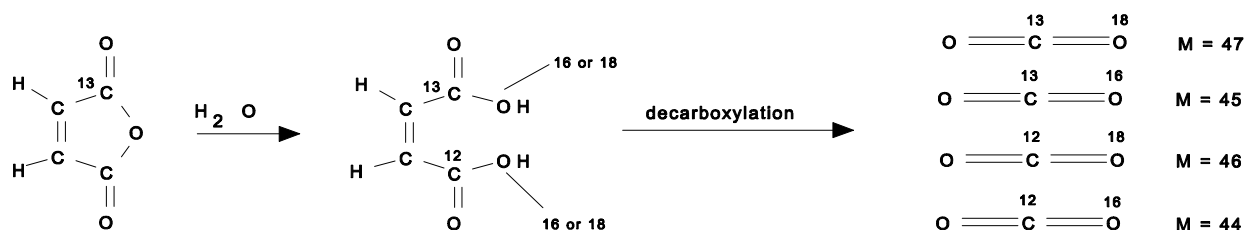

PROBLEM 5

Bacterial conversion of saccharose leads to (S)-(+)-2-hydroxypropanoic acid (L-(+)-lactic acid), which forms a cyclic ester out of two molecules. This dilactide can be polymerized to a polylactide, which is used in surgery.

- 5.1 Give the spatial structures and Fischer projection of L-(+)-lactic acid and its dilactide.
- 5.2 Sketch the structure of the polylactide discussed above (at least three units). What is its tacticity (iso-, syndio- or atactic)?
- 5.3 Draw the isomeric dilactides formed out of racemic lactic acid. Show the configuration of the chiral centres.

L-(+)-lactic acid is used for the preparation of the herbicide Barnon that is used against wild oats. In this case (+)-lactic acid is esterified with 2-propanol and then the hydroxyl group is treated with methanesulfonyl chloride. The product is then submitted to a S_N2 -reaction with 3-fluoro-4-chloro-phenylamine, where the methanesulfonate group leaves as CH_3SO_3^- . Finally a benzoyl group is introduced with the help of benzoyl chloride.

- 5.4 Draw the Fischer projection of the various consecutive reaction products.

SOLUTION

5.1

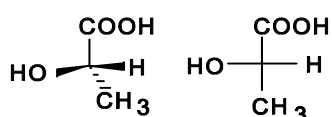

L-(+)-lactic acid and its Fischer projection

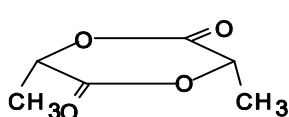

Dilactide of L-(+)-lactic acid - spatial formula

5.2

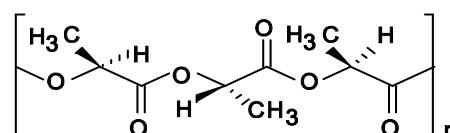

Polylactide of L-(+)-lactic acid

- 5.3 Dilactides of racemic lactic acid with the following configurations:

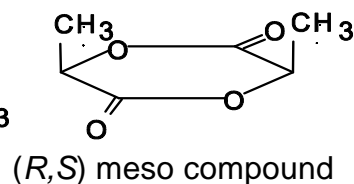
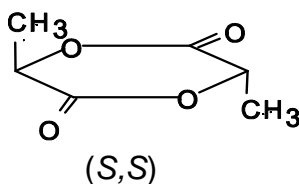
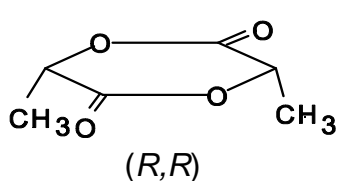

5.4

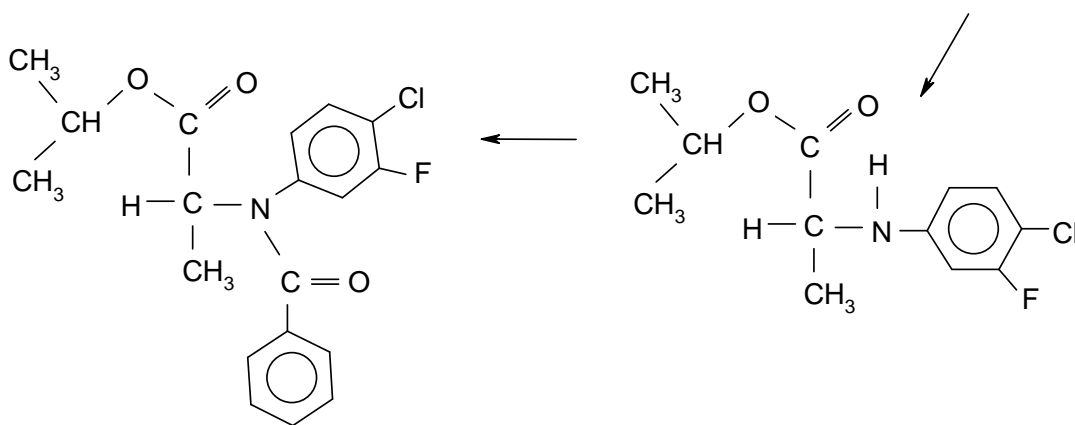
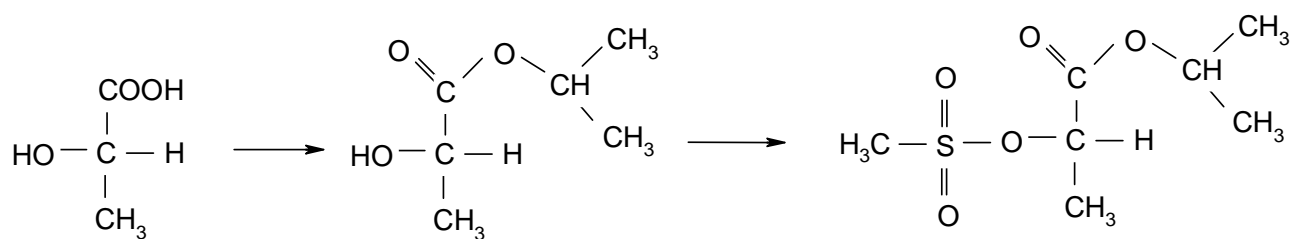

Barnon

PROBLEM 6

In recombinant DNA technology specific endonucleases can recognize and hydrolyse the phosphoric ester bound in each of both strands. Cla I for example hydrolyses the bond between two nucleotides in the sequence:



- 6.1 Give the base sequence of the complementary strand in the 5' - 3' direction and indicate with arrows the location where the hydrolysis by Cla I would occur.
- 6.2 How often on average will this sequence occur in one strand of DNA molecule of 10^5 base pairs? You can assume that the four bases occur equally often and that they randomly distribute in the two chains.

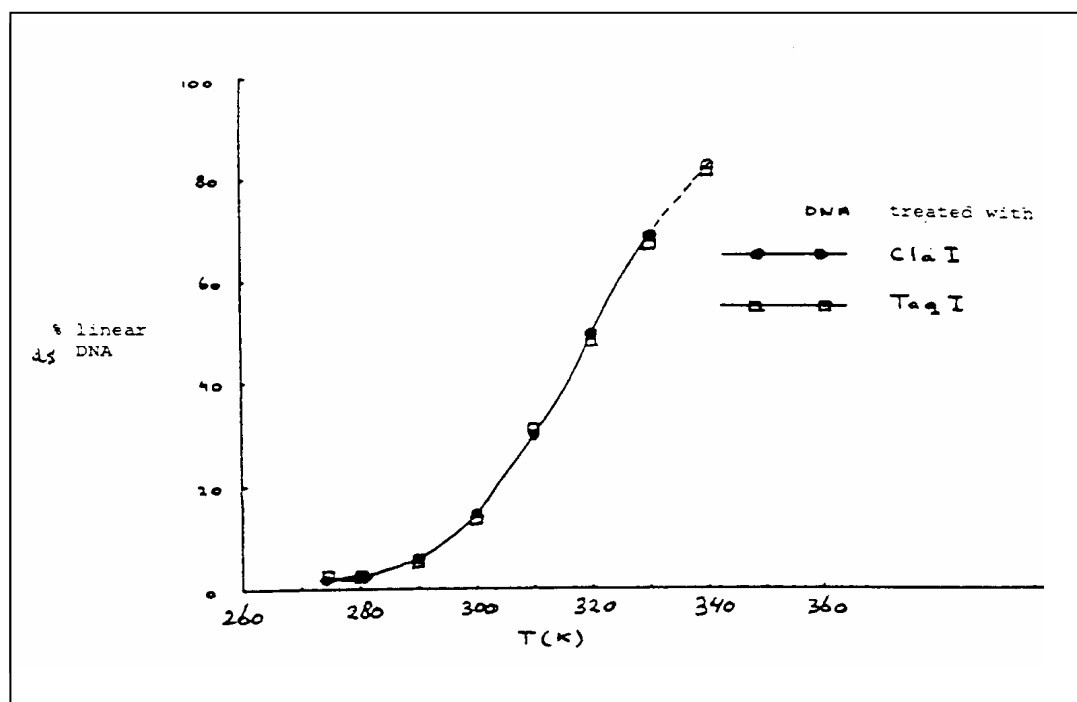

Taq I hydrolyses a long double strand DNA molecule into fragments which are on average 256 base pairs long. The 3' end of these fragments treated by cleavage turns out to be a thymine(T)- and the 5' end a cytosine(C) -end.

- 6.3 How long is the sequence recognized by Taq I?
- 6.4 Give the two possible base sequences (in the direction 5' - 3') which form the recognition pattern for Taq I (must obviously have some symmetry).

The DNA of a phage which occurs as a close circle contains only 5'-pApTpCpGpApT-3' sequence in each of the two strands. After treatment with ClaI equilibrium is established: circular DNA \rightleftharpoons linear DNA.

6.5 Give a schematic drawing of the circular and linear molecules. Indicate the bases adjacent to the cleaving site in both strands. Indicate also the 3' and 5' ends.

In Fig. 1 the percentage of linear DNA is given as a function of temperature, measured in a solution of 0.15 M NaCl buffered with citrate at pH = 6.5. With Taq I as cleavage enzyme, the same curve is obtained.

6.6 Is the reaction as written endothermic or exothermic? Explain your answer.

6.7 Show, considering the information given, which of the two base sequences of the answer to **6.4** is the correct one.

6.8 What would look the curve for Taq I like if the recognition pattern would have been the other possibility of d)?

A large DNA molecule is cut into fragments with the aid of Cla I. One fragment is isolated, purified and mixed in the ratio of 1:1 with phage DNA which was also cleaved with Cla I. Thereby recombinant molecules can be formed through the reaction:



6.9 Would the enthalpy of this reaction be positive, negative or about zero? Explain your answer.

6.10 Which combination of temperature, DNA concentration and ionic strength (high or low in each case) will give the maximum percentage of recombinant molecules?

SOLUTION

6.1 5' - pTpApGpCpT \pC

6.2 The probability of the sequence given is $(1/4)^6 = 1/4096$. Thus, this specific sequence may occur in the DNA $10^5/4096 = 24.4$ times on average

6.3 The sequence recognized by Taq I is 2 base pairs, that is 4 bases.

6.4 The sequence is 5' - pTpCpGpA - 3' or 5' - pGpApTpC - 3'

6.5

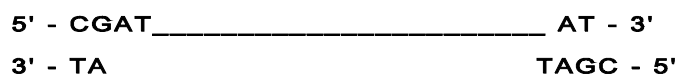
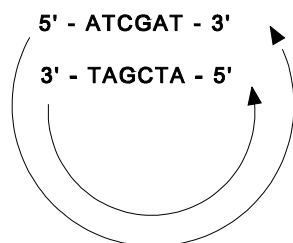

6.6 The reaction is endothermic. The reaction has a positive enthalpy, since the hydrogen bonds between the bases G and C in the complementary strands are broken.

6.7 The two relations show the same dependence on temperature. Therefore, the enthalpy of the two reactions is roughly the same. Then the interaction of the double helix must be identical and therefore we must choose TCGA for the first recognition sequence of question **6.4**. The cleavage in the two cases mentioned in d) occurs as follows:

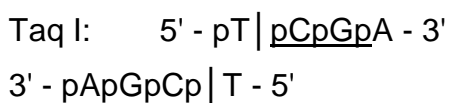
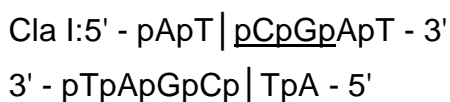

6.8 The following curve would be obtained:

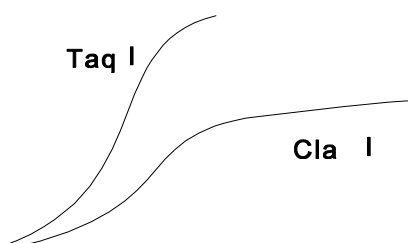

6.9 ΔH is negative.

6.10 Low temperature, low DNA concentration and high ionic strength will give the maximum percentage of recombinant molecules.

PROBLEM 7

The equilibrium constant of the reaction $A_{(g)} + 2 B_{(g)} \rightleftharpoons 2 C_{(g)}$ is $K_p = 10.0 \text{ MPa}^{-1}$. The starting materials are supplied at 25 °C and heated to 100 °C where complete equilibration takes place. Below 100 °C the reaction rate is negligibly small. The whole process is executed continuously in a stationary state. The boiling points at 0.1 MPa of **A**, **B**, and **C** are 40 °C, 80 °C, and 60 °C, respectively. The three compounds have the same heat of evaporation: $q \text{ J mol}^{-1}$. The heat capacities of **A**, **B**, and **C** may be neglected. A schematic diagram of a distillation is shown below (Fig. 1).

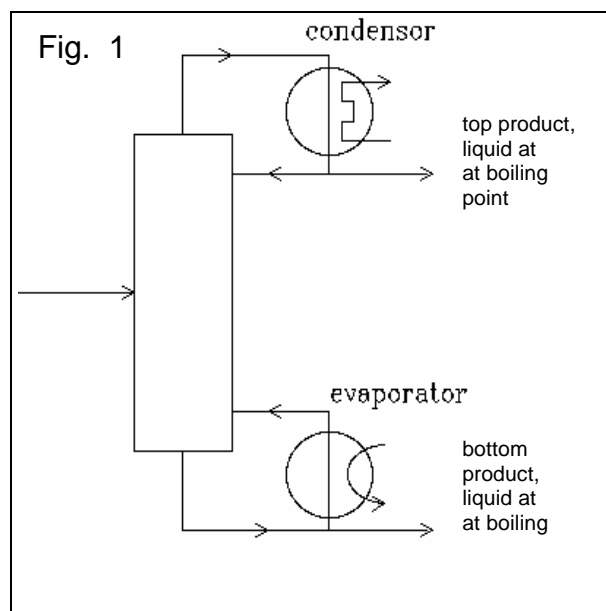

The total heat used at each of the two distillations is $3q \text{ J mol}^{-1}$ (of the top product). Apart from distillation columns (each with its own evaporator and condenser) the pieces of apparatus shown of Fig. 2 are available.

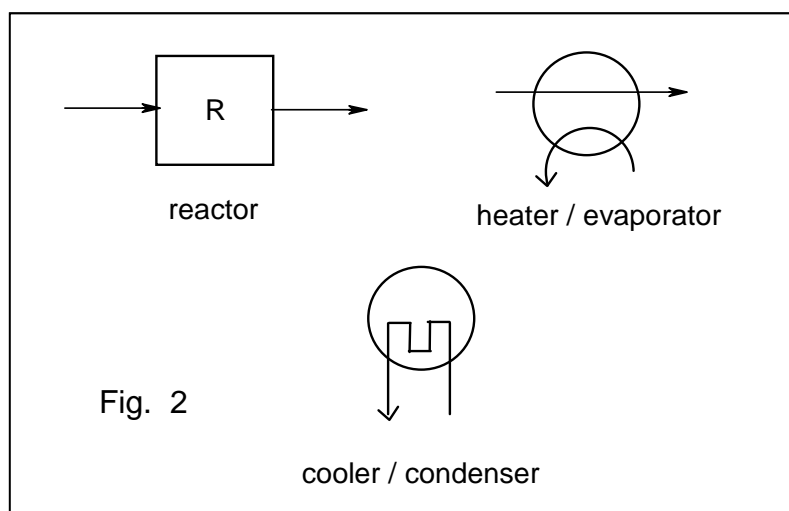

7.1 Draw a flow diagram of the process in which all flows are given (flow sheet) and in which the starting materials are used as efficiently as possible using as few pieces of apparatus as possible.

- 7.2 Express the equilibrium constant in terms of the degree of conversion and of total pressure for the case that the feed to the reactor is stoichiometric. What is the value of the degree of conversion when total pressure is 0.100 MPa?
- 7.3 Number all flows. Calculate the composition of each flow in mol s⁻¹ for a rate of production of 1 mole of **C** per second under the conditions of part b.
- 7.4 In what respect can the reaction conditions influence the composition of the mixture that leaves the reactor? (Refer to question b.)
- 7.5 The process requires energy. For the conditions of b explain where energy should be supplied in the flow diagram drawn in part a. Derive an expression for the total energy needed.

SOLUTION

- 7.1 In order to minimize the pieces of apparatus, the liquids A and B should evaporate together. For complete consumption of the starting materials, A and B are recirculated as feed for the reactor. The scheme of figure depicts the solution.

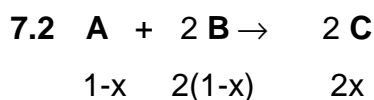
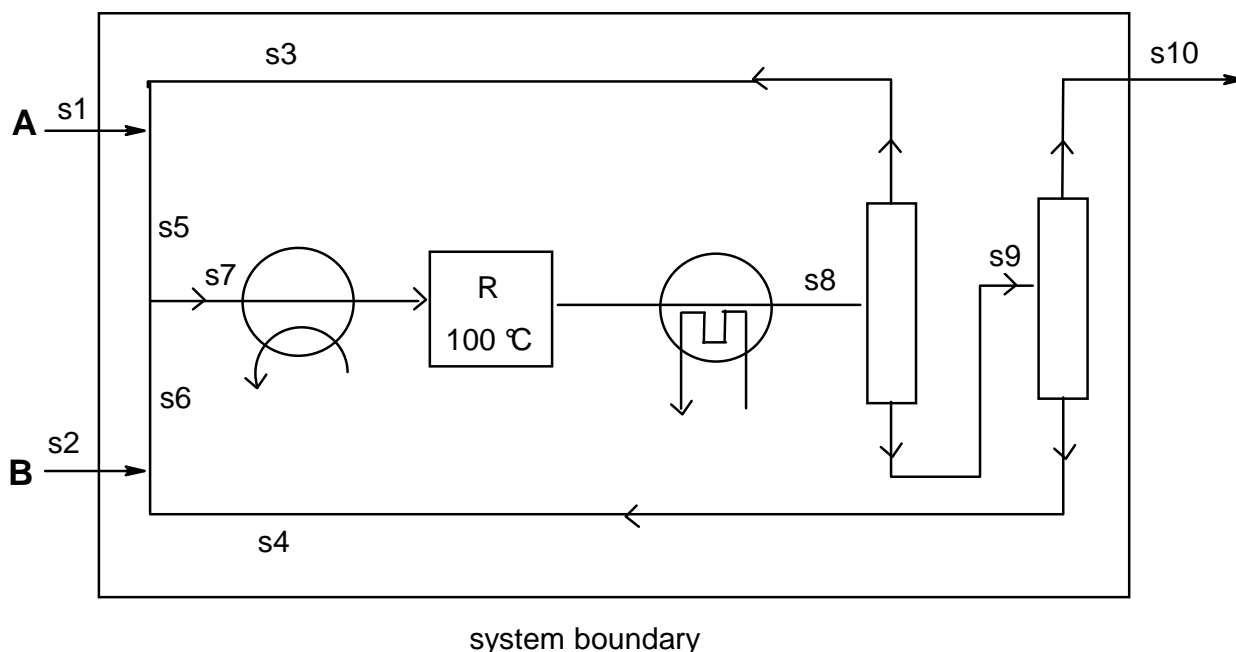

In total $3-x$ mol gases are present after conversion. Supposing that the input of **A** is a mol (S5) and the input of **B** b mol (S6) we can write for the equilibrium:

$$K_p = \frac{p_C^2}{p_A \times p_B^2} = 10.0$$

If x mol of **A** are converted, S8 contains $(a - x)$ mol of **A**, $(b - 2x)$ mol of **B** and $2x$ mol of **C**. Therefore S8 contains $(a - x) + (b - 2x) + 2x = (a + b - x)$ moles and we can write for the partial pressures of A and B:

$$p_A = \frac{a - x}{a + b - x} P \quad p_B = \frac{b - 2x}{a + b - x} P \quad p_C = \frac{2x}{a + b - x} P$$

Therefore the equilibrium can be written as

$$K_p = \frac{(2x)^2}{(a - x)(b - 2x)^2} \times \frac{a + b - x}{P} = 10$$

7.3 For $P = 0.10$ we obtain: $4x^2a + 4x^2b - 4x^3 = ab^2 - 4abx + 4ax^2 - xb^2 + 4x^2b - 4x^3$ and wherefrom:

$$0 = ab^2 - 4abx - xb^2 \text{ and since } b \neq 0: \quad 0 = ab - 4ax - bx$$

With a total inflow of 0.5 mol s^{-1} **A** (S1) and 1 mol s^{-1} **B** (S2), the amount of **C** leaving the reactor (S10) is 1 mol s^{-1} . So $2x = 1$ and $x = 0.5$. The relation between a and b can be written as: $a = b / (2b - 4)$. Since the feed is stoichiometric $a : b = 1 : 2$. This leads to $b = 3$ and $a = 1.5$.

All flows (mol/s) can be calculated now:

$$s_1 = 0.5 \text{ mol s}^{-1} \text{ A}$$

$$s_2 = 1 \text{ mol s}^{-1} \text{ B}$$

$$s_3 = 1.5 - 0.5 = 1 \text{ mol s}^{-1} \text{ A}$$

$$s_4 = 3 - 1 = 2 \text{ mol s}^{-1} \text{ B}$$

$$s_5 = a = 1.5 \text{ mol s}^{-1} \text{ A}$$

$$s_6 = b = 3 \text{ mol s}^{-1} \text{ B}$$

$$s_7 = 1.5 \text{ mol s}^{-1} \text{ A} + 3 \text{ mol s}^{-1} \text{ B}$$

$$s_8 = 1 \text{ mol s}^{-1} \text{ A} + 2 \text{ mol s}^{-1} \text{ B} + 1 \text{ mol s}^{-1} \text{ C}$$

$$s_{10} = 1 \text{ mol C}$$

$$s_{9_1} = 2 \text{ mol B} + 1 \text{ mol C}; \quad s_{9_2} = 1 \text{ mol A} + 1 \text{ mol C}$$

7.4 By increasing the pressure, the equilibrium is pushed towards the side with the smallest number of molecules that means to the right side. Another possibility is changing the ratio of the feed. i. e. $a : b$. According to $a = b / (2b - 4)$, b will be larger

if a decreases and vice versa. Because the net enthalpy change is 0, temperature has no effect.

7.5 Energy must be supplied for heating the evaporator and for the two distillation columns. The total energy consumed of the flow in scheme can be calculated as follows:

$$Q_1 = q \cdot S_7 + 3q \cdot S_3 + 3q \cdot S_{10} = 10.5 q$$

PRACTICAL PROBLEMS

Introduction:

The experimental assignment consists of the synthesis and subsequently, the analysis of amminenickel(II) chloride: $\text{NiCl}_x(\text{NH}_3)_y$.

The synthesis proceeds in three steps:

- Preparation of a solution of nickel nitrate from nickel and concentrated nitric acid (green solution), time required about 20 min.
- Preparation of amminenickel(II) nitrate (blue crystals)
- Preparation of amminenickel(II) chloride (blue-violet crystals)

The analysis encompasses the determination of the percentages of the three components (ammonia, nickel and chlorine) of the salt, according to the instructions given in 2.

PROBLEM 1 (practical)

Synthesis of the nickel(II) salt:

All work on the synthesis must be carried out in the fume hood. Use of (safety) glasses is obligatory. If necessary use other safety equipment, such as rubber gloves and pipetting balloons.

- Put a "dubbeltje" (Dutch coin of 10 c, containing 1.5 g of nickel), in a 100 ml conical flask (Erlenmeyer flask) and add 10 ml of concentrated nitric acid (65 %). Fit the flask with an "air cooled" condenser (no water) and heat the contents on a hot plate until a violent reaction occurs. Continue heating carefully until all metal is dissolved. Cool the green solution in an ice-water mixture.

Write in the report form the equation of the chemical reaction that has occurred.

- Add, under continuous cooling, in small portions 25 ml of ammonia solution (25 %) to the ice cold solution. As soon as about 15 ml has been added, salt crystals start to precipitate. Having added all ammonia solution, filter the cold solution through a sintered glass filtering crucible by applying a vacuum with an aspirator. Wash the crystals three times with small portions of a cold ammonia solution (25 %). Remove as much liquid as possible from the crystalline mass by maintaining the vacuum.

- c) Dissolve the moist crystalline mass in 10 ml of hydrochloric acid (18 %). Cool the blue solution in an ice-water mixture and then add slowly 30 ml of a solution of 30 g ammonium chloride in 100 ml of ammonia solution (25 %). This yields a blue-violet coloured crystalline mass. Cool the mixture and filter as in b). Wash with ammonia solution (25 %), then with ethanol and finally with diethyl ether. Leave the crystals on air until all ether has evaporated. Determine the mass of the dry product and record this on the report form.
-
-

PROBLEM 2 (practical)Analysis of the Nickel Salt:

For the analysis of the salt, only one sample solution is prepared. The determination of the components is achieved by titrating each time 25 ml of the sample solution in duplicate.

For the determination of the ammonia and chlorine content a back titration is carried out. For that purpose a certain amount of reagent is added in excess. The total amount of reagent, available for the sample, is determined by following the same procedure for 25 ml of a blank solution. This titration should not be carried out in duplicate.

Prepare the following solutions:

A) Sample solution:

Pipette 25.0 ml of 1.6 M nitric acid into a volumetric flask of 250 ml. Add a sample of about 1.2 g of the ammonienickel(II) chloride and dilute with water to a volume of 250 ml.

B) Blank solution:

Pipette 25.0 ml of the same 1.6 M nitric acid and dilute it with water to a volume of 250 ml.

Note:

- 1) For the chlorine determination use conical (Erlenmeyer) flasks with a ground glass stopper.
- 2) The nitric acid contains a small amount of hydrochloric acid. The total acid content is 1.6 M.

a) *Determination of the ammonia content*

Titrate the solutions with a standard solution of NaOH (about 0.1 M). Indicator: methylred, 0.1 % solution in ethanol.

Calculate the percentage of ammonia in the salt.

b) *Determination of the nickel content*

Add about 100 ml of water, 2 ml of ammonia solution (25 %) and 5 drops of murexide solution to the nickel solution, which now should have a yellow colour. Titrate the solution with a standard solution of EDTA (about 0.025 M) until a sharp colour change from yellow to violet is observed. Calculate the percentage of nickel in the salt.

c) *Determination of the chlorine content*

Execute the titration as quickly as possible after the addition of the reagent!

Add to each solution 25 ml of 0.1 M silver nitrate solution. Add about 5 ml of toluene, shake vigorously, add indicator and titrate with the standard solution of ammonium thiocyanate (-rhodanide, about 0.05 M) until a permanent colour change to red is observed. At the end of the titration, shake vigorously again. The red coloration should persist.

Indicator: 1 ml of a saturated solution of iron(III) sulphate.

Calculate the percentage of chlorine in the salt.

Data: Relative atomic masses: H = 1, Cl = 35.5, Ni = 58.7, N = 14.

Questions:

Calculate from the results obtained the molar ratio of the components to two decimal points and enter this on the report form in the format: Ni : Cl : NH₃ = 1.00 : x : y.
